

A painting of a wooden post with a chain and green leaves against a blue sky. The post is dark brown and has a chain of metal links hanging from it. The leaves are various shades of green and are attached to a vine that winds around the post. The sky is a light blue with some white clouds. The overall style is painterly and somewhat abstract.

Creative Highlights By  
**Serena Bales**

[designsbysserena.com](http://designsbysserena.com)

Employment at

**FLIGHT SAFETY  
SERVICES CORP.**

Serena  
2011



# VISUAL DESIGNER

Centennial, CO ▪ November 1998 – July 2001

- Created detailed technical digital illustrations, extensive photo retouching, and animations for eLearning Computer Base Training (CBT) courses for the US Air force.
- Team Lead Designer for the C-141C Paper Based Training (PBT) Courses.
- Provided creative support to the Engineering proposal groups and Human Resource Department.

**Results:** Increase in Airforce pilot safety training. 100% in pilot training of the TCAS TAWS instrument for the C5, C141 and KC135 air-planes.

**Teamed with:** copywriters, editors, developers, programmers SME's, designers, managers, instructional designers, vendors, printers, photographers, and internal and external clients.

**Client:** US Air Force

## SKILLS

### PC platforms

### Software Used

#### Adobe

- Photoshop
- Illustrator
- PageMaker
- Lightwave

#### Microsoft

- Word
- PowerPoint
- Excel
- Outlook

### Job Duties

#### Art Direction

- Project/team lead
- Photo direction

#### Illustration

- Concept sketching
- Technical and realistic
- Digital and traditional
- 2D & 3D

# PAPER BASE (PBT) and COMPUTER BASED (CBT) TRAINING

## Computer Base Training

The images on this page are technical drawings created while I worked for FlightSafety Services Corp. The division I worked for provided training for the Air Force Pilots that flew the C141, C5 and the KC135 airplanes. My role was to create a base panel and for each part that toggled or moved there would be a new graphic created to overlay using Authorware to animate it. An example would be the toggle switches moving up or down, lights on or off, different codes displayed, numbers changing and etc. There where a team of digital artist and each was assigned different training courses to work on at one time. I created the panels shown on this page along with all the graphics that where to be used for the animations. The delivery of these courses where done by computer.

## Paper Based Training

I was the Team Lead designer for the C131 paper based training courses that consisted of over 10,000 technical drawings done in Illustrator and placed either into a Word documents or PowerPoint courses per the request of the AirForce.

At FlightSafety there was a team digital artists, instructional designers, SME's, programmers, editors, project managers and Air Force collaborators.

All interactive training given to the US AirForce. Not for civilian viewing. Here is the address to Flight Safety Service Corp.  
[www.flightsafety.com/fs\\_service\\_government\\_military\\_conm.php?p=b1](http://www.flightsafety.com/fs_service_government_military_conm.php?p=b1)



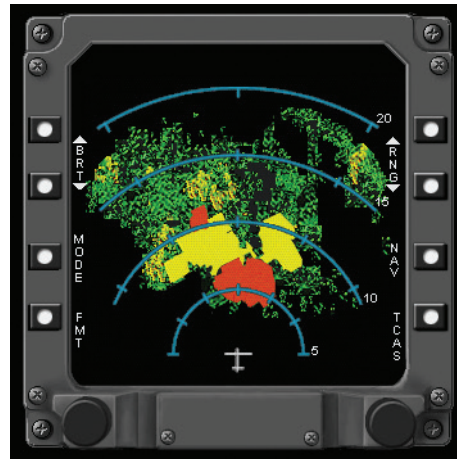
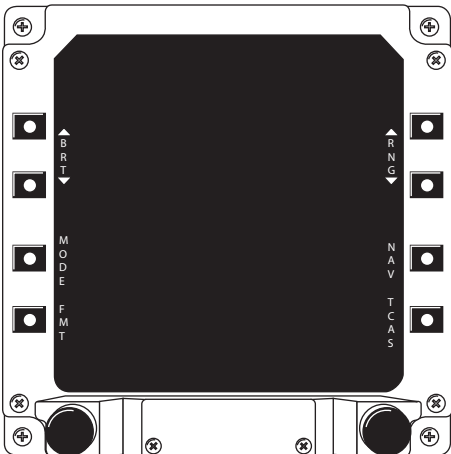
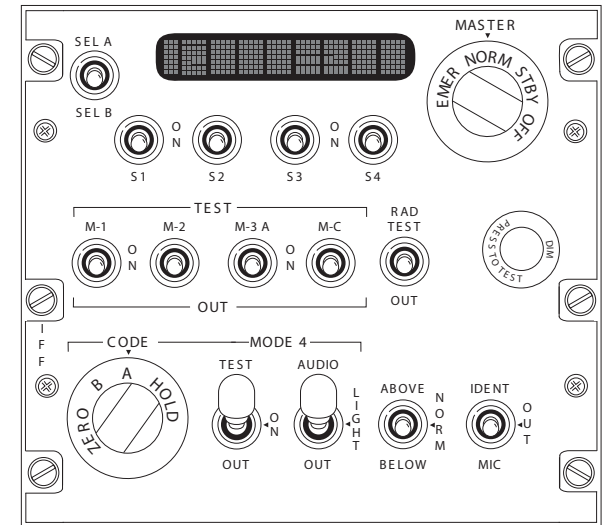

# ILLUSTRATION

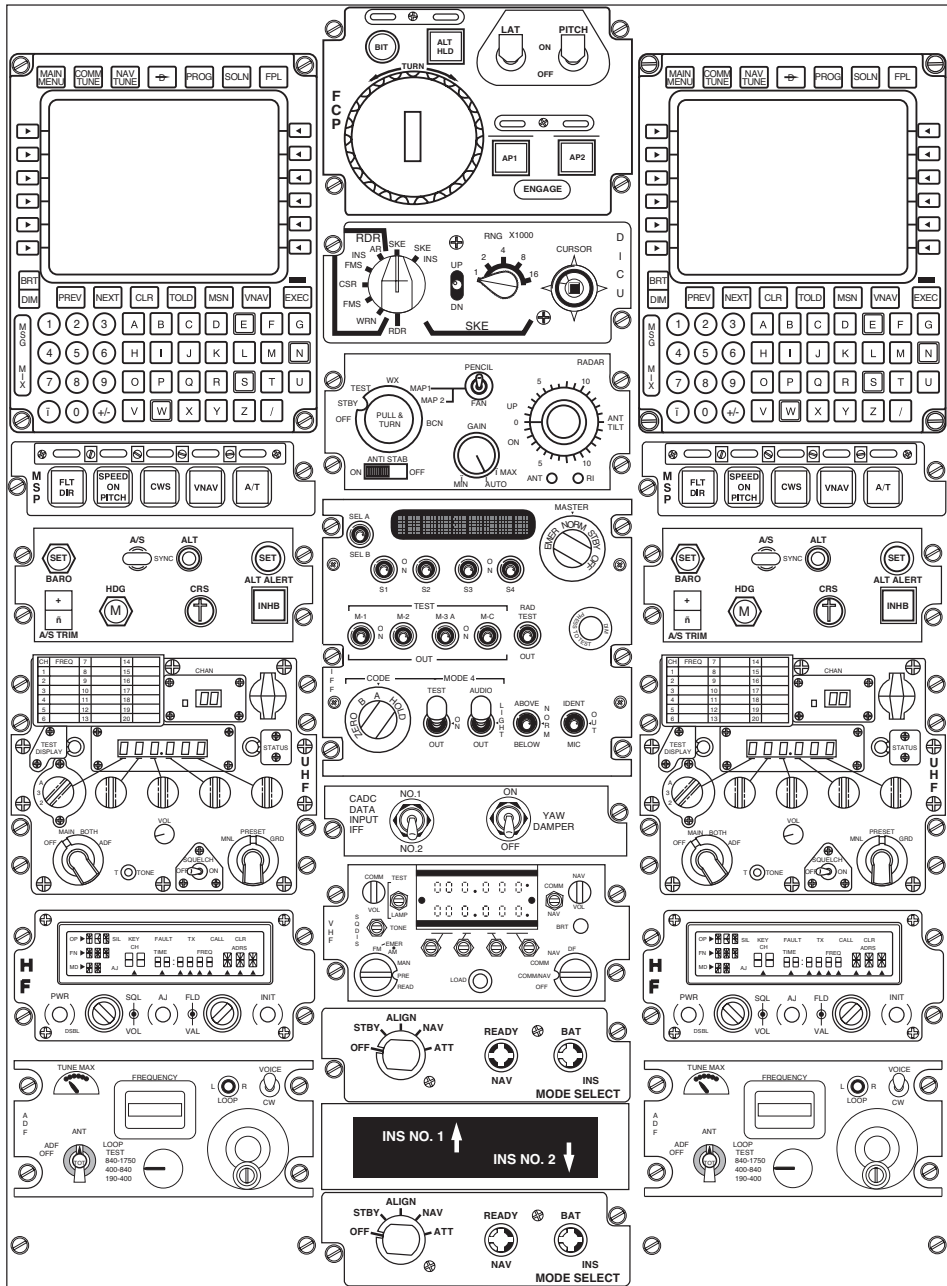

760031.015

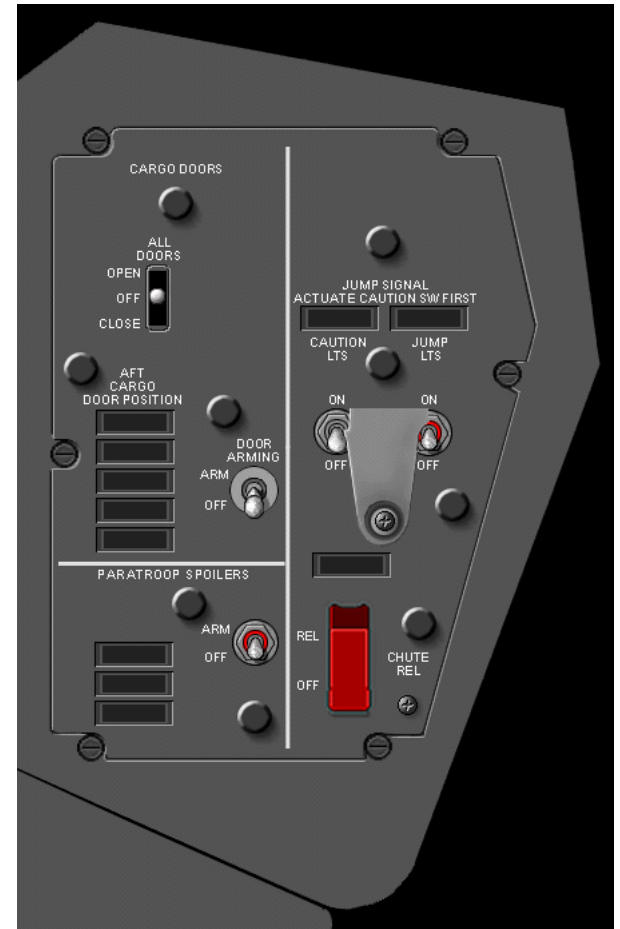

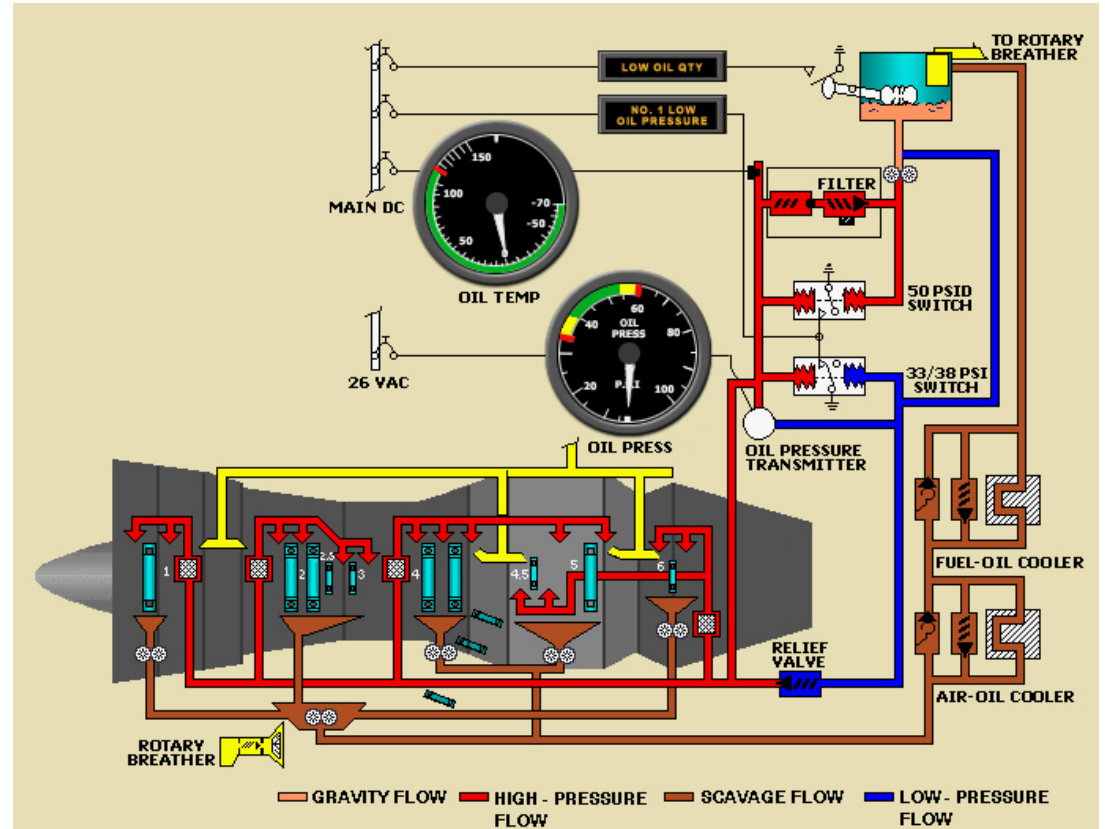
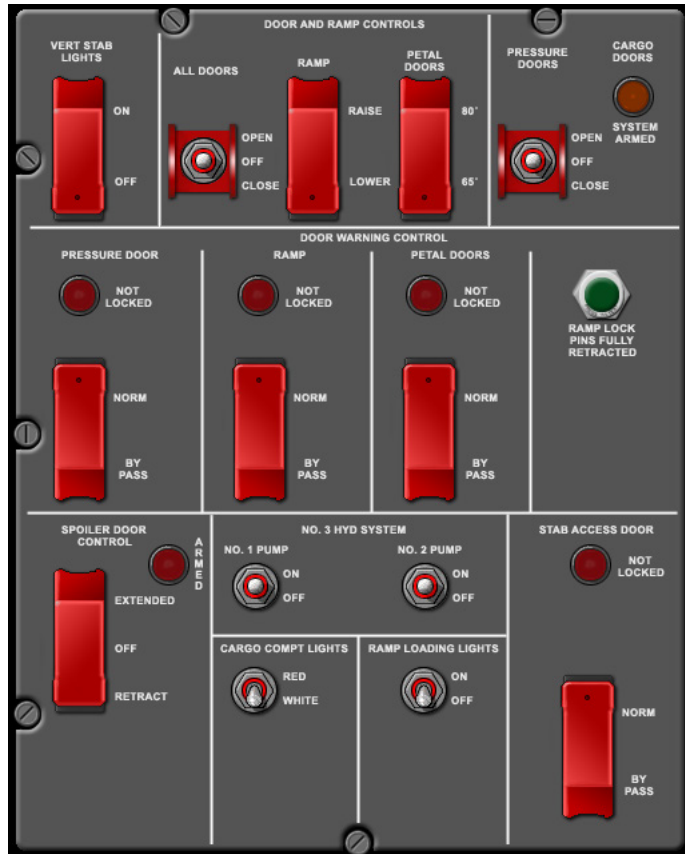

# ILLUSTRATION

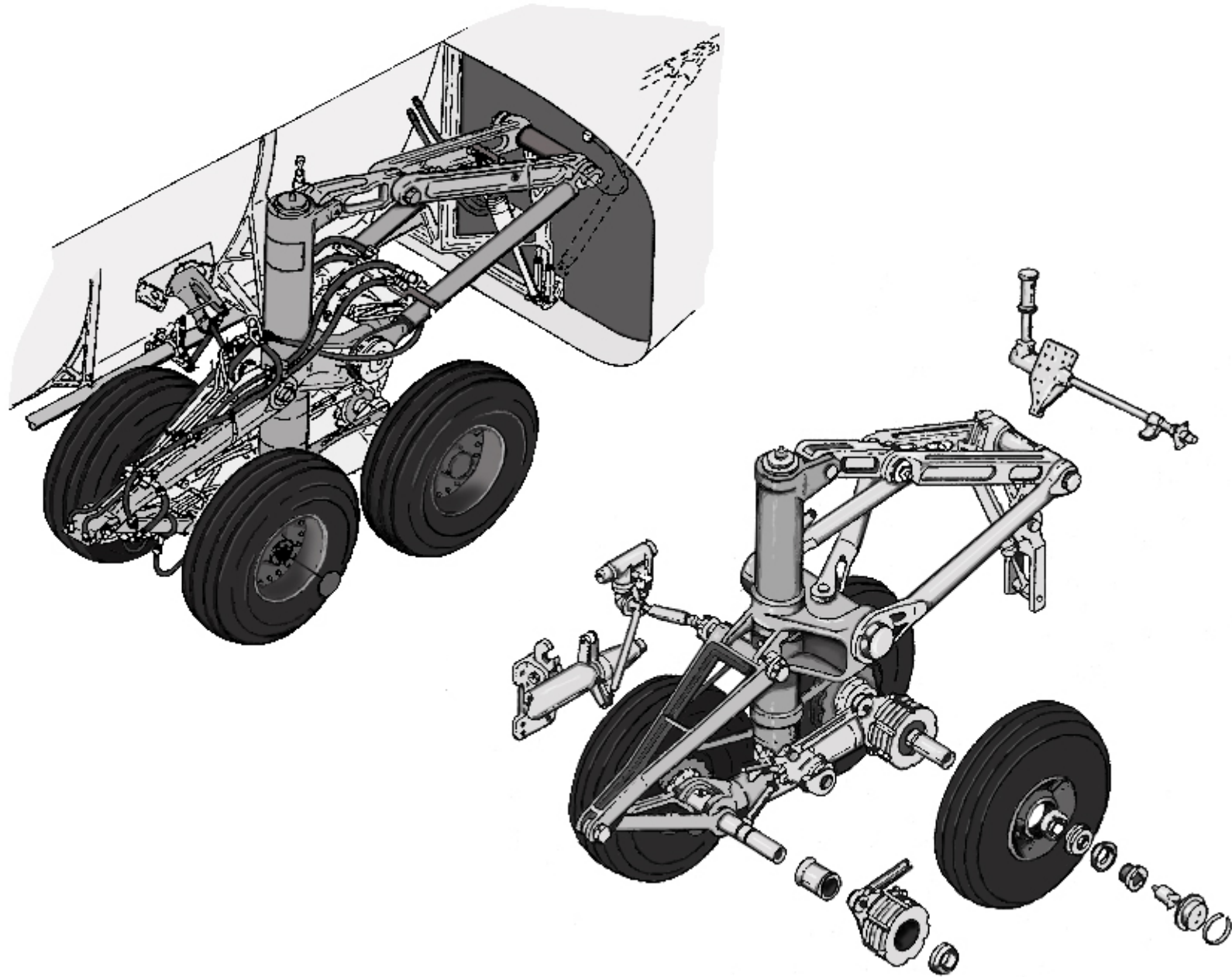



Let your  
career  
SOAR  
at  
**FlightSafety**  
SERVICES CORPORATION



*Five reasons you'll rise above the rest with FlightSafety...*

- We're the world's foremost aviation trainer.
- We're a world leader in military aircrew training.
- We're among the largest providers of aircrew training programs for the Department of Defense.
- More than thirty locations mean terrific opportunities to relocate.
- We offer a comprehensive benefits package.

Whatever your vision—to teach military flight crews, maintain simulators, or develop courseware for our current (C-5, C-141, KC-135, V-22, JSTARS, JPATS) or future programs—log on and take off with the leader at [www.fssc.com](http://www.fssc.com) or send your resume today.



Phil Marshall, Altus AFB, Oklahoma, C-5 Site Manager: "I'm proud to be in a leadership position in a company known worldwide for its excellence in military aircrew training." Ed Yamamoto, C-5 program Training Systems Support Center Manager: "I can't imagine a more positive, supportive environment in which to learn from peers and teach to others."

## FlightSafety

SERVICES CORPORATION

3333 S. Bannock Street, Suite 100  
Englewood, Colorado 80110

Recruitment Specialist e-mail:  
[emp@fsi061.flightsafety.com](mailto:emp@fsi061.flightsafety.com)

phone 303.783.1023  
fax 303.783.8557

*An Equal Opportunity Employer*

## FlightSafety

SERVICES CORPORATION

"Let FlightSafety ease the transition. File your flight plan with a world leader in aircrew training."



Through these portals pass the best trained aircrews flying the most challenging missions while protecting America's freedoms. Why not continue to do your part? Join the FlightSafety team and ensure future aircrews receive continued high quality training.



### INSTRUCTOR OPPORTUNITIES

- Pilot Instructors
- Flight Engineer Instructors

Use your experience and knowledge to train the next generation of aircrew members. Train through the use of state-of-art simulators, computer based training and stand-up classroom training.

### TECHNICAL OPPORTUNITIES

- Simulator Maintenance Technicians
- IT Technicians

Our Technicians ensure the safety, reliability, accuracy and functionality of our simulators, and computer systems. As a Sim Tech, a basic electronics course is required.



Call today to learn more about these and other opportunities with FlightSafety.

e-mail: [emp@fssc.com](mailto:emp@fssc.com)  
fax: 303-783-8557  
phone: 800-523-1775 x3206

[www.fssc.com](http://www.fssc.com)  
*An equal opportunity employer.*



FlightSafety  
SERVICES CORPORATION

United States Air Force  
C/KC-135  
**PACER  
CRAG**  
Rockwell

BOOM  
OPERATOR





**Serena Bales**  
865 Clover Lane  
Oregon, WI 53575  
608.501.9004

[serena@designsbyserena.com](mailto:serena@designsbyserena.com)

[designsbyserena.com](http://designsbyserena.com)

*Serena*  
2008